

Instructions for PM42 Upgrade

450 Cemetery ST #206 Norcross, GA USA 30071
(770)441-7992 FAX (770)441-0759
Web Site: www.digitrax.com



PM42 Upgrade Kit Upgrade from PM4 to PM42

Add two more levels of user selectable
short circuit detection sensitivity to your existing PM4s

PM4/PM42 Top View

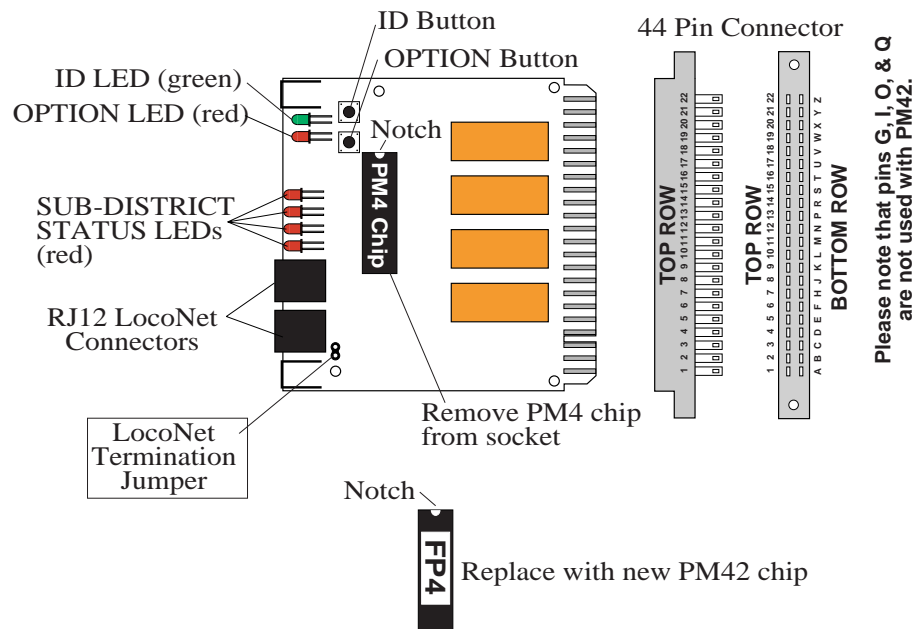

1. Use a thin bladed screwdriver to lift the PM4 chip out of the socket.
2. Carefully straighten any bent pins on the new chip (included with this kit).
3. Plug the new chip (included in this kit) in the orientation shown here.
Note the notch on the end of the chip for proper orientation.
4. Be sure the replacement chip is fully seated.
5. Set up OpSws (Option Switches) according to instructions in the PM42 manual